

## TA2 HÁROMFÁZISÚ MOTORCSALÁD / THREE PHASE MOTOR SERIES

Hatásfok osztály/Efficiency class: IE2

Talpak/Feet: szerelhető/removable

Egyéb jellemzők/Other features: 3xPTC; IP 55; F oszt.; S1, S9

Teljesítmény Rated power P <sub>n</sub> (kW)	Motor méret Frame size	I <sub>n</sub> (A) 400V	n (min <sup>-1</sup> )	η (%) 100%	cos φ	Nyomaték Torque M <sub>n</sub> (Nm)	M <sub>start</sub> /M <sub>n</sub>	M <sub>max</sub> /M <sub>n</sub>	I <sub>start</sub> /I <sub>n</sub>	Zaj Noise dB(A)	Tömeg Weight (kg)	Tokozás Housing		
<b>2 pólus / 2 pole - 50Hz</b>														
Δ/Y - 400/690V	5,5	112M	10,26	2920	88,6	0,87	18,0	3,5	4,1	10,1	88	32	Alumínium Aluminium	
	9,2	132M	16,66	2930	89,7	0,89	30,0	3,4	4,2	10,8	78	51		
	11	132M	19,51	2935	90,8	0,90	35,8	4,0	4,1	12,6	78	59		
	<b>4 pólus / 4 pole - 50Hz</b>													
	5,5	112M	11,25	1435	87,9	0,80	36,6	3,8	3,6	8,3	83	37		
	9,2	132M	17,40	1455	89,5	0,85	60,3	3,0	3,2	8,7	72	60		
11	132M	20,58	1460	90,5	0,85	71,9	3,3	3,6	9,2	72	68			

**B3**

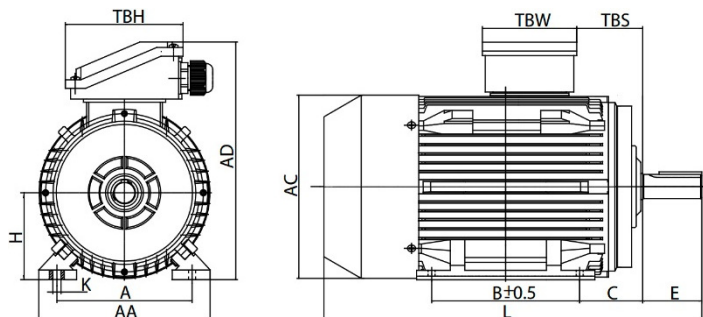

**B5**

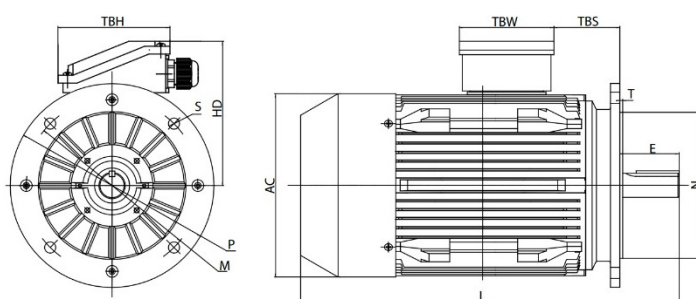

**B14**

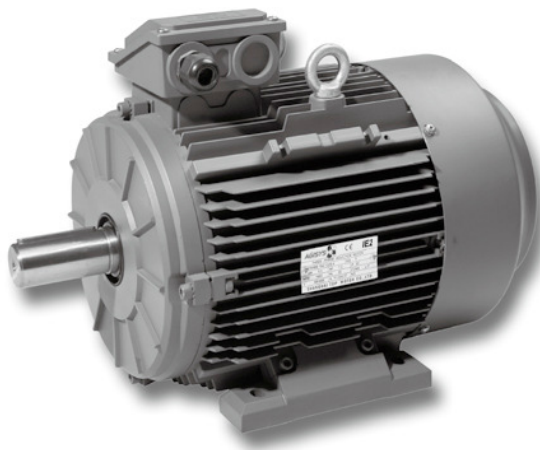
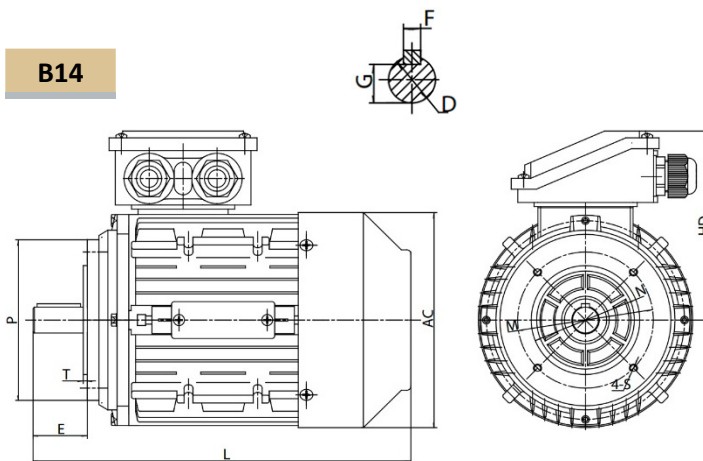

Motor méret Frame size	Méreték / Dimensions												
	Tengely méretek / Shaft dimensions					Általános méretek / General dimensions							
	D	E	F	G	K	AA	AD	HD	AC	L	TBS	TBW	TBH
112M	∅28	60	8	24	∅12	230	291	179	220	405	29	118	118
132M	∅38	80	10	33	∅12	255	332	200	259	505	29	118	118

Motor méret Frame size	Talp és perem méretek / Feet and flange dimensions													
	B3				B5					B14				
	H	A	B	C	N	M	P	S	T	N	M	P	S	T
112M	112	190	140	70	180	215	250	4-∅15	4	110	130	160	M8	3,5
132M	132	216	178	89	230	265	300	4-∅15	4	130	165	200	M10	3,5

SKF	
Csapágyak / Bearings	
Első / Front	Hátsó / Back
6306 C3	6206 C3
6308 C3	6208 C3

A műszaki adatok előzetes értesítés nélkül változhatnak. / Specifications are subject to change without notice.